

---

 TECHNICAL DATA SHEET

# PMAFIX IP66 - BVWD-P - Fitting

## 90° elbow, PG thread

### PMA



One-piece, polyamide fitting for flexible non-metallic conduit



#### Applications:

- For cable protection systems in a wide range of applications

#### Features & Benefits:

- Easy installation: simple push fit assembly
- Very high impact resistance
- Vibration-proof connection to PMA conduits
- High conduit pull-out strength
- Can be easily re-opened with a screwdriver
- Very good chemical properties
- Fits both conduit profiles - fine (T) and coarse (G)

#### Ingress protection:

- IP66 (EN/IEC 60529)

#### Materials:

- High-grade, specially formulated polyamide 6

#### Compatible with:

- PMAFLEX Pro Conduits
- PMAFLEX Multilayer Conduits
- PMAFLEX Conduits
- PMA Smart Line Conduits

#### Conforms to:

- EN 45545-2 HL3 (R22 & R23)
- NFPA 130
- UL 94 (V0)
- UL 1696 (UL file E80294)
- CSA C22.2 No. 227.3-05 (CSA file LL 88703)

#### Weathering resistance:

- Very good UV resistance and weathering characteristics, particularly in black

#### Colour:

- Black
- Grey

#### Chemical properties:

- Please refer to [www.pma.ch](http://www.pma.ch) (Technical Information / Chemical Resistance)

#### Environmental properties:

- Free from halogens and cadmium
- RoHS and REACH compliant

**Product selection:**

Part no.		Thread size	Conduit size	Dimensions in mm (nom.)				Weight	Packing unit
black	grey	PG	NW	g	d2	A	B	kg/100 pcs	pcs/PU
BVWD-P07MGT-8	SVWD-P07MGT-8	7	7	8.0	16.5	29.0	35.0	0.5	100
BVWD-P07MGT-11	SVWD-P07MGT-11	7	7	11.0	16.5	32.0	35.0	0.5	100
BVWD-P070GT-8	SVWD-P070GT-8	7	10	8.0	20.0	31.0	39.5	0.7	50
BVWD-P070GT-11	SVWD-P070GT-11	7	10	11.0	20.0	34.0	39.5	0.7	50
BVWD-P072GT-8	SVWD-P072GT-8	7	12	8.0	23.5	35.5	44.5	0.8	50
BVWD-P072GT-11	SVWD-P072GT-11	7	12	11.0	23.5	38.5	44.5	0.8	50
BVWD-P09MGT-8	SVWD-P09MGT-8	9	7	8.0	20.0	29.0	36.5	0.5	100
BVWD-P09MGT-11	SVWD-P09MGT-11	9	7	11.0	20.0	32.0	36.5	0.5	100
BVWD-P090GT-8	SVWD-P090GT-8	9	10	8.0	20.0	31.0	39.5	0.6	50
BVWD-P090GT-11	SVWD-P090GT-11	9	10	11.0	20.0	34.0	39.5	0.6	50
BVWD-P092GT-8	SVWD-P092GT-8	9	12	8.0	23.5	35.5	44.5	1.0	50
BVWD-P092GT-11	SVWD-P092GT-11	9	12	11.0	23.5	38.5	44.5	1.0	50
BVWD-P11MGT-8	SVWD-P11MGT-8	11	7	8.0	23.0	29.0	38.0	0.6	100
BVWD-P11MGT-11	SVWD-P11MGT-11	11	7	11.0	23.0	32.0	38.0	0.6	100
BVWD-P110GT-8	SVWD-P110GT-8	11	10	8.0	23.0	31.0	41.0	0.6	50
BVWD-P110GT-11	SVWD-P110GT-11	11	10	11.0	23.0	34.0	41.0	0.6	50
BVWD-P112GT-8	SVWD-P112GT-8	11	12	8.0	23.5	35.5	46.0	1.0	50
BVWD-P112GT-11	SVWD-P112GT-11	11	12	11.0	23.5	38.5	46.0	1.0	50
BVWD-P13MGT-8	SVWD-P13MGT-8	13.5	7	8.0	26.0	29.0	39.5	0.6	50
BVWD-P13MGT-11	SVWD-P13MGT-11	13.5	7	11.0	26.0	32.0	39.5	0.6	50
BVWD-P130GT-8	SVWD-P130GT-8	13.5	10	8.0	26.0	31.0	42.5	0.7	50
BVWD-P130GT-11	SVWD-P130GT-11	13.5	10	11.0	26.0	34.0	42.5	0.7	50
BVWD-P132GT-8	SVWD-P132GT-8	13.5	12	8.0	26.0	35.5	47.5	1.1	50
BVWD-P132GT-11	SVWD-P132GT-11	13.5	12	11.0	26.0	38.5	47.5	1.1	50
BVWD-P137GT-8	SVWD-P137GT-8	13.5	17	8.0	29.5	40.5	58.5	1.5	50
BVWD-P137GT-11	SVWD-P137GT-11	13.5	17	11.0	29.5	43.5	58.5	1.5	50
BVWD-P167GT-8	SVWD-P167GT-8	16	17	8.0	29.5	40.5	58.5	1.3	50
BVWD-P167GT-11	SVWD-P167GT-11	16	17	11.0	29.5	43.5	58.5	1.3	50
BVWD-P213GT	SVWD-P213GT	21	23	12.0	37.0	54.0	67.0	2.0	30
BVWD-P299GT	SVWD-P299GT	29	29	12.0	44.0	61.5	74.5	6.5	20
BVWD-P366GT	SVWD-P366GT	36	36	13.0	53.5	72.0	98.0	6.6	20
BVWD-P488GT	SVWD-P488GT	48	48	13.0	66.0	85.5	111.0	10.2	10

Our customer service dept. or local distribution partner will be pleased to help you concerning product availability and lead time

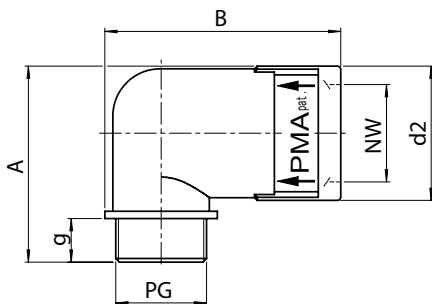

<b>Mechanical Properties:</b>	<b>Value:</b>	<b>Test parameters:</b>	<b>Test method:</b>
Tensile modulus	1'200 ... 3'700 N/mm <sup>2</sup>		ISO 527
Tensile strength	45 ... 65 N/mm <sup>2</sup>		ISO 527
Notched bar impact test	4 ... 20 kJ/m <sup>2</sup>		ISO 180/1C
Vibration and shock standard	Cat. 2		IEC 61373, IEC 60068-2-27 / -64

<b>Thermal properties:</b>	<b>Value:</b>	<b>Test parameters:</b>	<b>Test method:</b>
Continuous application temperature	- 50 ... + 105 °C		PMA DO 9.21-4510
Upper application temperature	+ 120°C	(20'000 h)	PMA DO 9.21-4360
Short-term	+ 160 °C	(168 h)	PMA DO 9.21-4360

<b>Fire safety properties:</b>	<b>Value:</b>	<b>Test parameters:</b>	<b>Test method:</b>
Fire performance	non flame-propagating		IEC EN 61386-1
Flame class	V0		UL 94

Fire hazard level	HL3		EN 45545-2 (R22)
Oxygen index	> 32 %		EN ISO 4589-2
Smoke density	< 150 Ds max.		EN ISO 5659-2 (25 kW/m <sup>2</sup> )
Toxicity	< 0.75 CIT <sub>NLP</sub>		NF X 70-100-1/-2: (600°C)

Fire hazard level	HL3		EN 45545-2 (R23)
Oxygen index	> 32 %		EN ISO 4589-2
Smoke density	< 300 Ds max.		EN ISO 5659-2 (25 kW/m <sup>2</sup> )
Toxicity	< 1.5 CIT <sub>NLP</sub>		NF X 70-100-1/-2: (600°C)

Fire performance NFPA 130:			NFPA 130
- Flammability	compliant		ASTM E 162
- Smoke density	compliant		ASTM E 662

Heat and visible smoke	26.00 MJ/kg		ASTM E 1354
Smoke emission toxicity	compliant		Bombardier SMP 800-C
Smoke emission toxicity	compliant		Boeing BSS 7241

#### Content of delivery:

- Fitting with premounted conduit locking clip (AFN2)

#### Assembly instructions:

- Push-in with a slight twist and pull back slightly to ensure the conduit clicks into place
- Please consider the appropriate assembly instructions on [www.pma.ch](http://www.pma.ch)

ABB Switzerland Ltd,  
PMA Cable Protection  
Aathalstrasse 90  
8610 Uster, Switzerland  
Phone: +41 58 585 00 11  
pma-info@ch.abb.com  
[www.pma.ch](http://www.pma.ch)

Let's write the future.  
Together. **abb.com**

We reserve the right to make technical changes or modify the contents of this document without prior notice. With regard to purchase orders, the agreed particulars shall prevail. ABB Installation Products Inc. does not accept any responsibility whatsoever for potential errors or possible lack of information in this document.

We reserve all rights in this document and in the subject matter and illustrations contained therein. Any reproduction, disclosure to third parties or utilization of its contents – in whole or in parts – is forbidden without prior written consent of ABB Inc. Copyright © 2019 ABB Installation Products Inc. All rights reserved

