



# DES 24MX



## Modular frames for cables with and without connectors

### FEATURES

- Modular, limitless solution
- Multiple configurations with small and big grommets
- Frame screws in AISI304 Stainless Steel
- IP54
- Strain relief according to EN 62444
- Sturdy construction IK10
- External gasket included

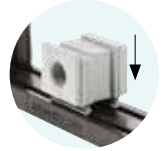

The DES 24MX splittable frames family is a modular solution for installations where a big quantity of cables need to be routed through electrical cabinets walls or panels. This solution is not only modular but it is also a general result that can be adopted as main cables entrance. Both cables with or without connector can be routed (40 for each module) and future updates can easily be organized in the cheapest and fastest way.





**Material:** PP+GF, halogens and silicones free

**Flammability:** self-extinguishing acc. UL94-V0

**Temperature:** -40°C... +155°C (static)

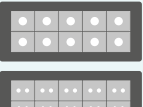
### RELATED PRODUCTS

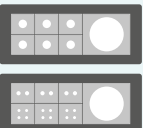
- SPP grommets (from page 48)
- SPG grommets (from page 54)
- DES caps (page 63)

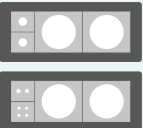
Model	Code	Some possible configurations for each module	Dimensions B x H (mm)	Max. cut-out (mm)	Pcs (/pack)
 DES 24MX2	1731010252		146 x 115	114 x 92	1
 DES 24MX3	1731010253		146 x 167	114 x 144	
 DES 24MX4	1731010254		146 x 219	114 x 196	
<b>Other models upon request</b>					
<b>Upon request</b>	1731991020	Set of 4 mounting screws in AISI304 with Black Geomet finishing			

### Dimensions (mm)

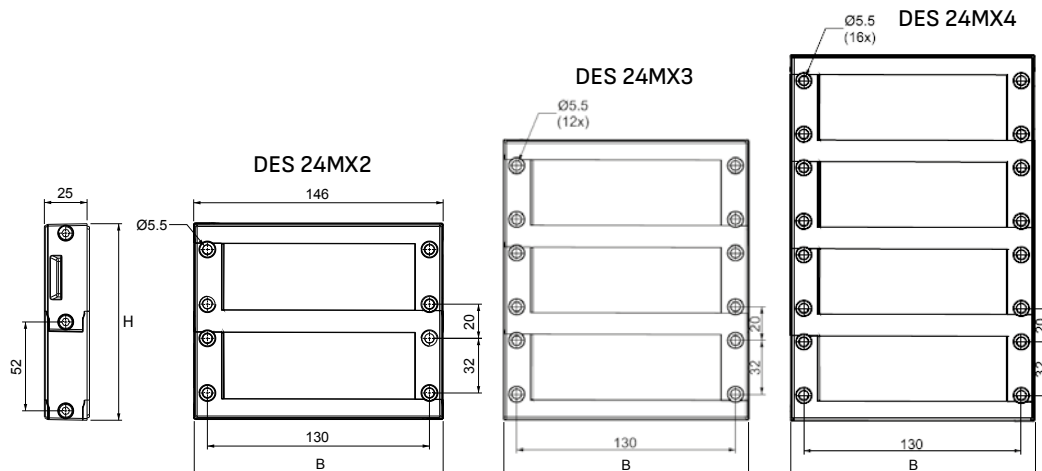

### Tutorial



IP54

NEMA 12



ECOLAB



IK10